

По вопросам продаж и поддержки обращайтесь: btn@nt-rt.ru

www.bently.nt-rt.ru

Архангельск (8182)63-90-72,
Астана+7(7172)727-132,
Белгород(4722)40-23-64,
Брянск(4832)59-03-52,
Владивосток(423)249-28-31,
Волгоград(844)278-03-48,
Вологда(8172)26-41-59,
Воронеж(473)204-51-73,
Екатеринбург(343)384-55-89,
Иваново(4932)77-34-06,
Ижевск(3412)26-03-58,
Казань(843)206-01-48,
Калининград(4012)72-03-81,
Калуга(4842)92-23-67,
Кемерово(3842)65-04-62,
Киров(8332)68-02-04,

Краснодар(861)203-40-90,
Красноярск(391)204-63-61,
Курск(4712)77-13-04,
Липецк(4742)52-20-81,
Магнитогорск(3519)55-03-13,
Москва(495)268-04-70,
Мурманск(8152)59-64-93,
Набережные Челны(8552)20-53-41,
Нижний Новгород(831)429-08-12,
Новокузнецк(3843)20-46-81,
Новосибирск(383)227-86-73,
Орел(4862)44-53-42,
Оренбург(3532)37-68-04,
Пенза(8412)22-31-16,
Пермь(342)205-81-47,
Ростов-на-Дону(863)308-18-15,

Рязань(4912)46-61-64,
Самара(846)206-03-16,
Санкт-Петербург(812)309-46-40,
Саратов(845)249-38-78,
Смоленск(4812)29-41-54,
Сочи(862)225-72-31,
Ставрополь(8652)20-65-13,
Тверь(4822)63-31-35,
Томск(3822)98-41-53,
Тула(4872)74-02-29,
Тюмень(3452)66-21-18,
Ульяновск(8422)24-23-59,
Уфа(347)229-48-12,
Челябинск(351)202-03-61,
Череповец(8202)49-02-64,
Ярославль(4852)69-52-93

Описание на акселерометры. Модели 200350, 200355



BENTLY
Nevada

200350 and 200355 Accelerometers

Bently Nevada™ Asset Condition Monitoring

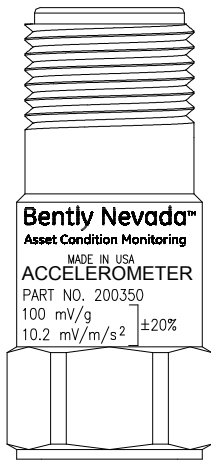

Description

The 200350 and 200355 Accelerometers are general purpose, case-mounted seismic transducers designed for use with Trendmaster® Pro Constant Current Direct Input Card 149811-02 and the Seismic Direct Input Card 164746-01.

The 200350 and 200355 Accelerometers are contained within a hermetically sealed, stainless steel case. The design provides an extremely rugged transducer, well suited for harsh industrial environments. Each transducer's top mounted, 2-pin connector (MIL-C-5015) allows for easy installation and removal of the interconnecting signal cable. A ¼-28 threaded hole on the bottom of the casing accommodates multiple mounting options.

The 200350 and 200355 Accelerometers contain a piezoelectric sensing device, which generates charge when subjected to vibration. This charge is then converted electronically to a differential voltage signal, which is proportional to the acceleration that is parallel to the sensitive axis of the transducer.



Application Alert

If housing measurements are being made for overall protection of the machine, consider the usefulness of the measurement for each application. Most common machine malfunctions (imbalance, misalignment, etc.) originate at the rotor and cause an increase (or at least a change) in rotor vibration. For housing measurements alone to be effective for overall machine protection, a significant amount of rotor vibration must be faithfully transmitted to the bearing housing or machine casing, or more specifically, to the mounting location of the transducer.

In addition, exercise care in the physical installation of the transducer. Improper installation can result in a degradation of the transducer's performance and/or the generation of signals that do not represent actual machine vibration.

Upon request, we can provide engineering services to determine the suitability of housing measurements for the machine in question and/or to provide installation



imagination at work

Specifications and Ordering Information
Part Number 164804-01
Rev. E (12/08)

Page 1 of 11

Specifications



Application Alert

Operation outside the specified limits will result in false readings or loss of machine monitoring.

Parameters are specified from +20 to +30 °C (+68 to +86 °F) and 100 Hz unless otherwise indicated.

Electrical

Specification		English Units	SI Units
Sensitivity 20%)	200350 (±	100 mV/g	10.2 mV/(m/s ²)
	200355 (± 5%)	100 mV/g	10.2 mV/(m/s ²)
Frequency Range 200350 (± 3dB)		30 to 600,000 cpm	0.5 to 10,000 Hz
	200355 (± 3dB)	12 to 600,000 cpm	0.2 to 10,000 Hz
Temperature Sensitivity		See Graph	See Graph
Measurement Range		± 50 g	± 490 m/s ²
Transverse Sensitivity	200350	= 7%	= 7%
	200355	= 5%	= 5%
Amplitude Linearity		± 1%	± 1%
Mounted Resonant Frequency	200350	1500 kcpm	25 kHz
	200355	1250 kcpm	20.8 kHz
Broadband Electrical Noise (1-10kHz) 200350		350 µg	3434 µm/s ²
	200355	50 µg	491 µm/s ²
Output Bias Voltage		8 to 12 VDC	8 to 12 VDC
Excitation Voltage		18 to 28 VDC	18 to 28 VDC
Constant Current Excitation		2 to 20 mA	2 to 20 mA
Settling Time (within 1% of bias)	200350	= 2.0 sec	= 2.0 sec
	200355	= 5.0 sec	= 5.0 sec
Output Impedance 200350		< 150 ohms	< 150 ohms
	200355	< 100 ohms	< 100 ohms
Discharge Time Constant	200350	= 0.3 sec	= 0.3 sec
	200355	= 0.8 sec	= 0.8 sec
Electrical Isolation (Case)		> 10 ⁸ ohms	> 10 ⁸ ohms

Environmental

Specification	English Units	SI Units
Operating Temperature Range	-65 to +250 °F	-54 to +121 °C
Shock Survivability	5,000 g pk	49,050 m/s ² pk
Relative Humidity	100% relative, condensing, non- submerged	
Enclosure Rating	IP68	IP68

Physical

Specification	English Units	SI Units
Size (Hex * Height)	11/16 in * 1.65 in	18 mm * 42.2 mm
200350	7/8in * 2.06in	22mm * 52.3mm
200355		
Weight	1.8 oz	51 gm
200350	3.3 oz	94 gm
200355		
Mounting Thread	¼-28 Female	¼-28 Female
Mounting Torque (Max)	2 to 5 ft*lb	2.7 to 6.8 N*m
Sensing Element	Ceramic	Ceramic
Sensing Geometry	Shear	Shear
Housing Material	Stainless Steel	Stainless Steel
Sealing	Welded Hermetic	Welded Hermetic
Electrical Connector	2-Pin Mil-C-5015	2-Pin Mil-C-5015
Electrical Connection Position	Top	Top

Hazardous Area Approvals

**Note: The 200355 does not have hazardous area approvals at this time.

200350

North America:

Ex ia / AEx ia IIC T4
Class I, Div 1 Groups A, B, C & D
When installed per dwg 175825
T4 @ -54 °C = Ta = 121 °C

Ex nL/AEx nA IIC T4
Class I, Div 2 Groups A, B, C & D
When installed per dwg 175825
T4 @ -54 °C = Ta = 121 °C

CSA 2007 1971585

ATEX:

 II 1 G
Ex ia IIC T4
LCIE 07 ATEX 6096 X
T4 @ -54 °C = Ta = 121 °C

 II 3 G
Ex nL IIC T4
LCIE 07 ATEX 6097 X
T4 @ -54 °C = Ta = 121 °C

EMC Directive (CE Mark)

Standards to which Conformity is Declared

CISPR 11 / EN 55011	Emissions: Class B, Group 1
EN61326 / A1	Emissions: Industrial Location
EN61326 / A1	Immunity: Industrial Location

Ordering Options

200350 – AA – BB – CC

AA Mounting Stud

- 00 1/4-28 SS w/Brass tip, 0.5 in
- 01 1/4-28 to M6 x 1.0 BeCu
- 02 1/4-28 to M8X1.25 BeCu
- 10 1/4-28 Adhesive Stud Mount
- 11 M6X1 Adhesive Stud Mount
- 12 M8X1.25 Adhesive Stud Mount

BB Tolerance Option

- 00 100 mV/g +/- 20 %

CC Approvals Option

- 00 No Approvals
- 01 Multi Approvals (North America, ATEX)

200355 – AA – BB – CC

AA Mounting Stud

- 00 1/4-28 SS w/Brass tip, 0.5 in
- 01 1/4-28 to M6 x 1.0 BeCu
- 02 1/4-28 to M8X1.25 BeCu
- 10 1/4-28 Adhesive Stud Mount
- 11 M6X1 Adhesive Stud Mount
- 12 M8X1.25 Adhesive Stud Mount

BB Tolerance Option

- 02 100 mV/g +/- 5 %

CC Approvals Option

- 00 No Approvals

Accessories

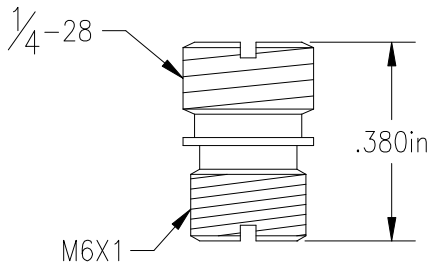
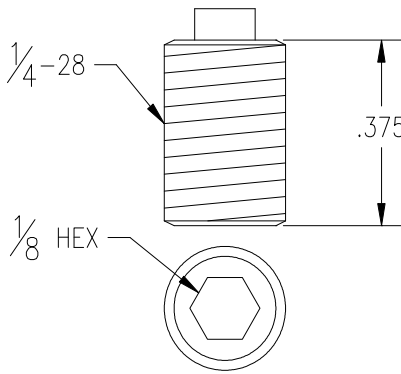
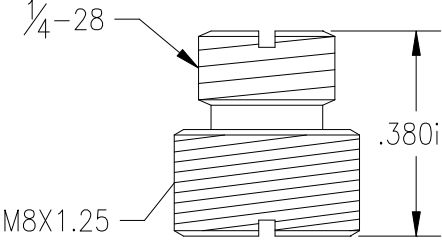
Title	Part Number	Notes
200350 and 200355 Accelerometer Manual	164803-01	
Trendmaster Pro System Manual	162411	
Trendmaster DSM Datasheet	149831-01	
Trendmaster DSM Manual	149823-01	
M6X1 Mount Stud	164372	
1/4 - 28 Mount Stud	164373	
M8X1.25 Mount Stud	167559	
1/4-28 Adhesive Mount Kit	167563-10	See Description Below
M6X1 Adhesive Mount Kit	167563-11	See Description Below
M8X1.25 Adhesive Mount Kit	167563-12	See Description Below
Splash Proof Cable **Not recommended for the 200350	CB2W100 - AAA	AAA = 015 ft AAA = 125 ft AAA = 032 ft AAA = 150 ft AAA = 064 ft AAA = 200 ft AAA = 112 ft

Standard Cable No Armor 2-conductor twisted, shielded 22 AWG cable with 2-socket moisture-resistant female connector at one end, terminal lugs at the other end.	9571 – AA	Minimum Length - AA = 02 ft Maximum Length - AA = 99 ft Increments of 01 ft
Standard Cable with Armor 2-conductor twisted, shielded 22 AWG cable with 2- socket moisture-resistant female connector at one end, terminal lugs at the other end.	84661 – AA	Minimum Length - AA = 03 ft Maximum Length - AA = 96 ft Increments of 01 ft

Adhesive Mounting Kits

Adhesive studs are sold in kits containing two threaded studs and two mounting pads. Also in the kit is a packet of acrylic adhesive and materials to mix its two components. A scouring pad and alcohol wipe are provided for preparing the mounting surface.

Adhesive Specification	English Units	SI Units
Temperature Range	-67 to +250 °F	-55 to 121 °C
Cure Time	24 Hour	24 Hour



Application Alert

Use of adhesive will attenuate high frequency components that may be present

DIMENSIONAL DIAGRAM

200350

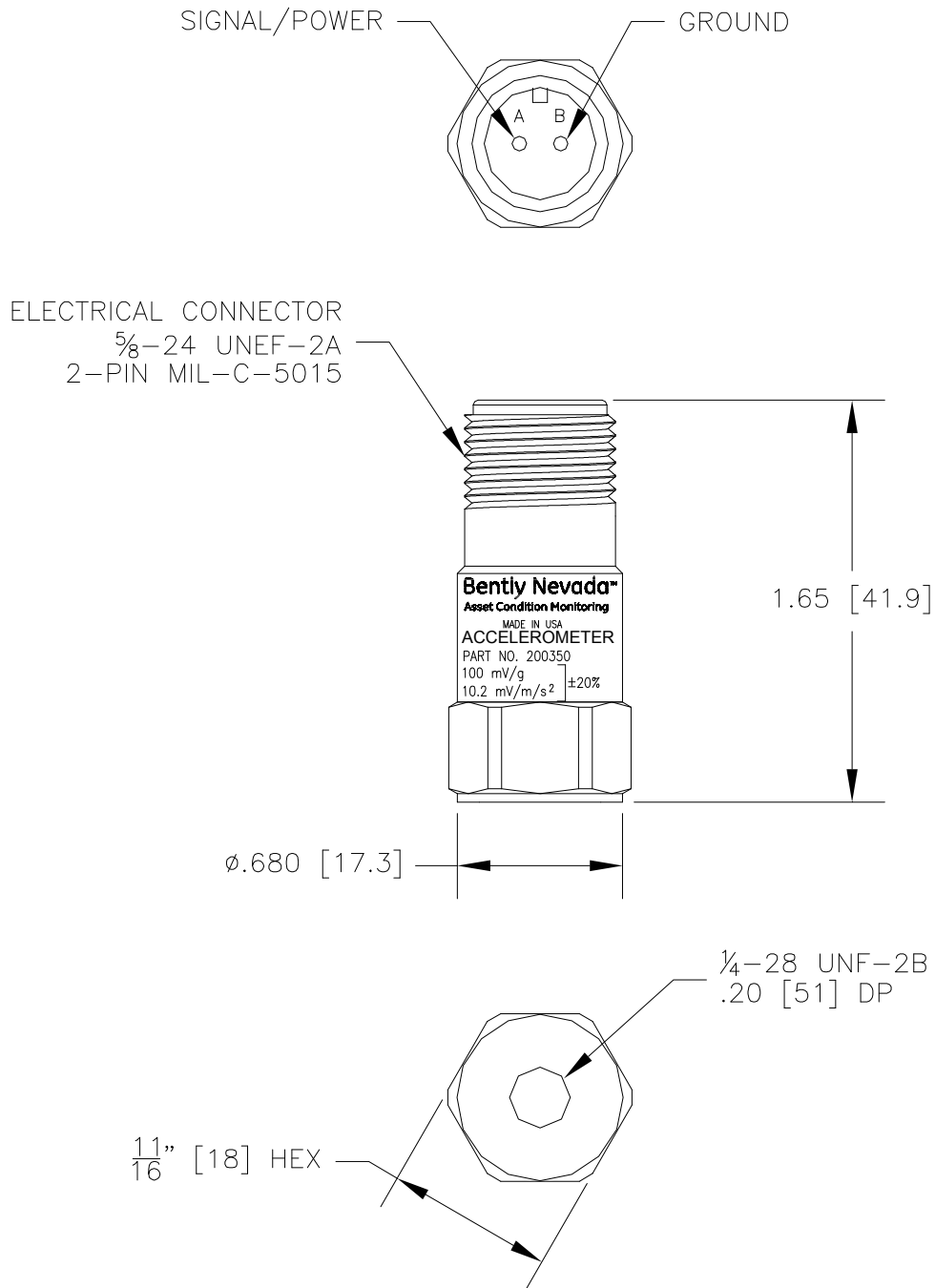

DIMENSIONS UNITS: in [mm]

200355

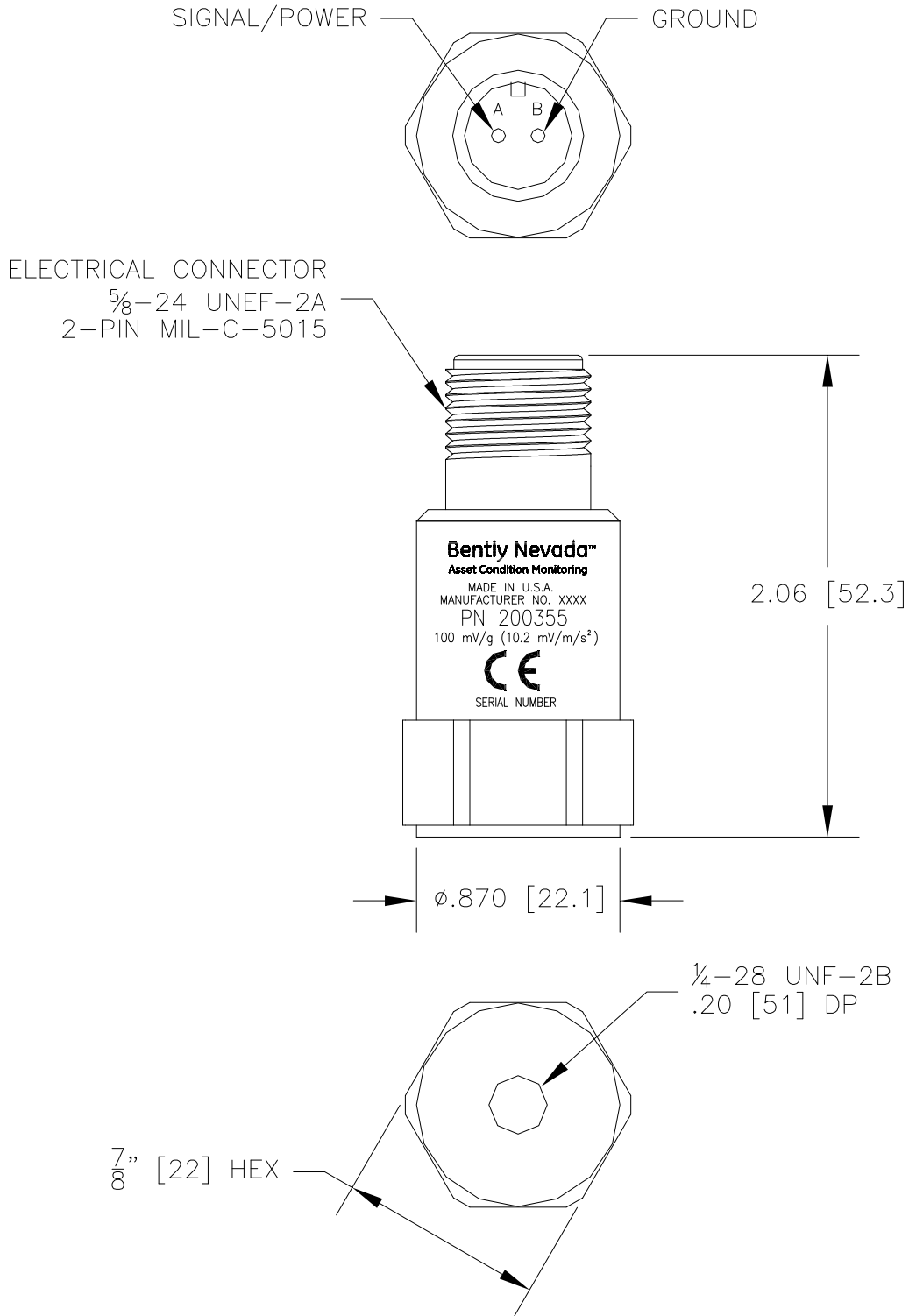

DIMENSIONS UNITS: in [mm]

Temperature Sensitivity Curve

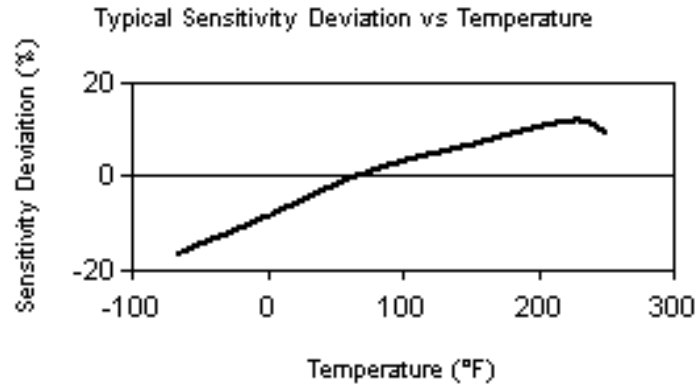

FREQUENCY AND PHASE RESPONSE CURVES

200350

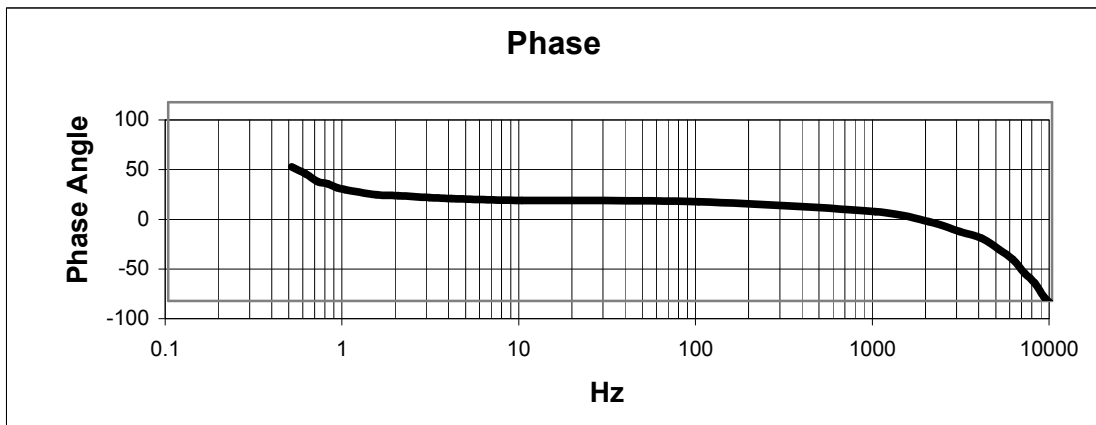
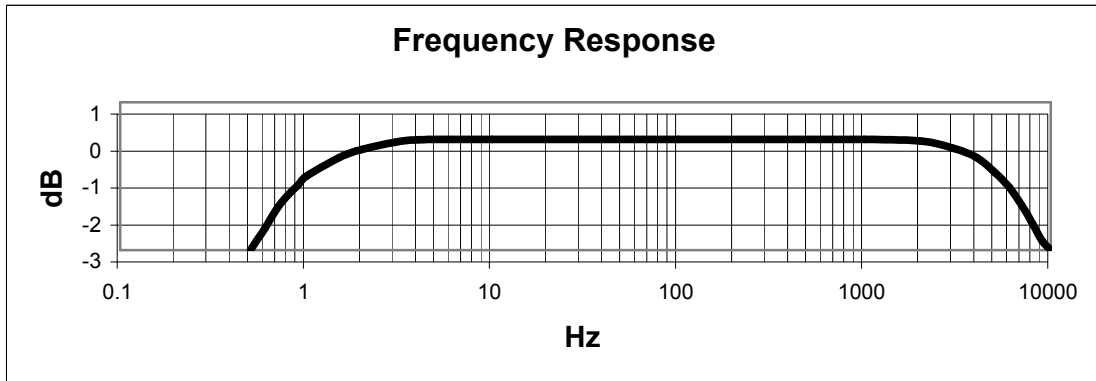

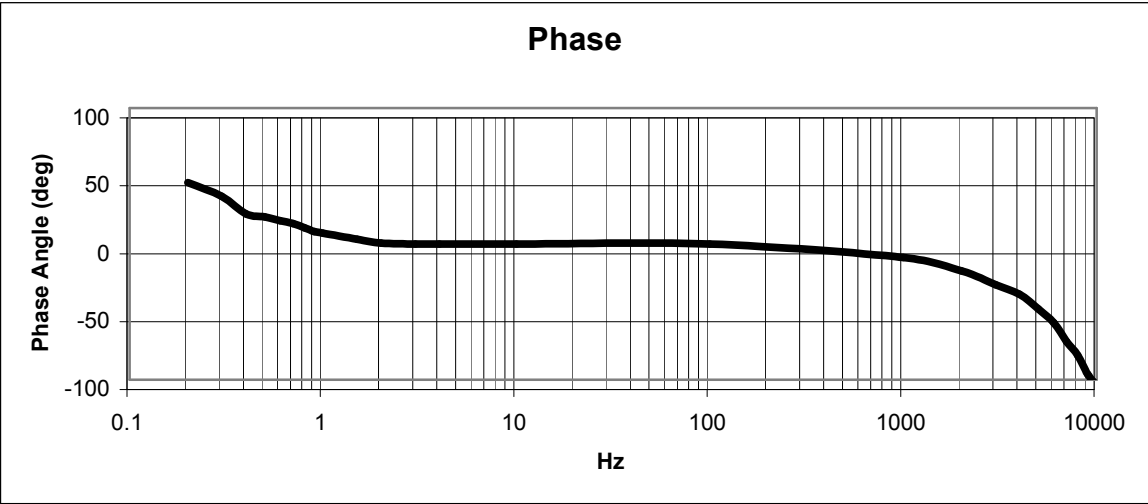
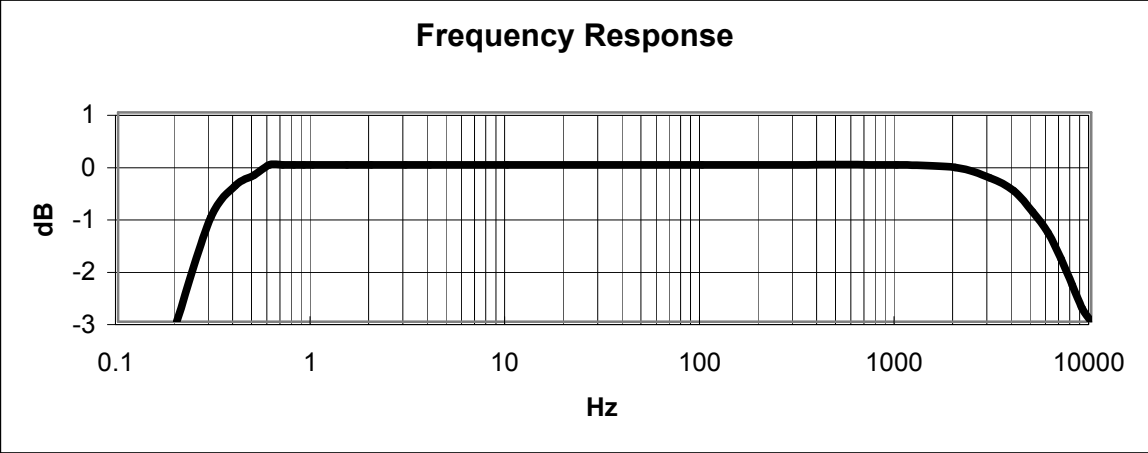

По вопросам продаж и поддержки обращайтесь: btn@nt-rt.ru

www.bently.nt-rt.ru

Архангельск (8182)63-90-72,
Астана+7(7172)727-132,
Белгород(4722)40-23-64,
Брянск(4832)59-03-52,
Владивосток(423)249-28-31,
Волгоград(844)278-03-48,
Вологда(8172)26-41-59,
Воронеж(473)204-51-73,
Екатеринбург(343)384-55-89
, Иваново(4932)77-34-06,
Ижевск(3412)26-03-58,
Казань(843)206-01-48,
Калининград(4012)72-03-81,
Калуга(4842)92-23-67,
Кемерово(3842)65-04-62,
Киров(8332)68-02-04,

Краснодар(861)203-40-90,
Красноярск(391)204-63-61,
Курск(4712)77-13-04,
Липецк(4742)52-20-81,
Магнитогорск(3519)55-03-13,
Москва(495)268-04-70,
Мурманск(8152)59-64-93,
Набережные Челны(8552)20-53-41
, Нижний Новгород(831)429-08-12,
Новокузнецк(3843)20-46-81,
Новосибирск(383)227-86-73,
Орел(4862)44-53-42,
Оренбург(3532)37-68-04,
Пенза(8412)22-31-16,
Пермь(342)205-81-47,
Ростов-на-Дону(863)308-18-15,

Рязань(4912)46-61-64,
Самара(846)206-03-16,
Санкт-Петербург(812)309-46-40,
Саратов(845)249-38-78,
Смоленск(4812)29-41-54,
Сочи(862)225-72-31,
Ставрополь(8652)20-65-13,
Тверь(4822)63-31-35,
Томск(3822)98-41-53,
Тула(4872)74-02-29,
Тюмень(3452)66-21-18,
Ульяновск(8422)24-23-59,
Уфа(347)229-48-12,
Челябинск(351)202-03-61,
Череповец(8202)49-02-64,
Ярославль(4852)69-52-93



BENTLY
Nevada