

По вопросам продаж и поддержки обращайтесь: [btn@nt-rt.ru](mailto:btn@nt-rt.ru)

[www.bently.nt-rt.ru](http://www.bently.nt-rt.ru)

Архангельск (8182)63-90-72,  
Астана+7(7172)727-132,  
Белгород(4722)40-23-64,  
Брянск(4832)59-03-52,  
Владивосток(423)249-28-31,  
Волгоград(844)278-03-48,  
Вологда(8172)26-41-59,  
Воронеж(473)204-51-73,  
Екатеринбург(343)384-55-89,  
, Иваново(4932)77-34-06,  
Ижевск(3412)26-03-58,  
Казань(843)206-01-48,  
Калининград(4012)72-03-81,  
Калуга(4842)92-23-67,  
Кемерово(3842)65-04-62,  
Киров(8332)68-02-04,

Краснодар(861)203-40-90,  
Красноярск(391)204-63-61,  
Курск(4712)77-13-04,  
Липецк(4742)52-20-81,  
Магнитогорск(3519)55-03-13,  
Москва(495)268-04-70,  
Мурманск(8152)59-64-93,  
Набережные Челны(8552)20-53-41,  
, Нижний Новгород(831)429-08-12,  
Новокузнецк(3843)20-46-81,  
Новосибирск(383)227-86-73,  
Орел(4862)44-53-42,  
Оренбург(3532)37-68-04,  
Пенза(8412)22-31-16,  
Пермь(342)205-81-47,  
Ростов-на-Дону(863)308-18-15,

Рязань(4912)46-61-64,  
Самара(846)206-03-16,  
Санкт-Петербург(812)309-46-40,  
Саратов(845)249-38-78,  
Смоленск(4812)29-41-54,  
Сочи(862)225-72-31,  
Ставрополь(8652)20-65-13,  
Тверь(4822)63-31-35,  
Томск(3822)98-41-53,  
Тула(4872)74-02-29,  
Тюмень(3452)66-21-18,  
Ульяновск(8422)24-23-59,  
Уфа(347)229-48-12,  
Челябинск(351)202-03-61,  
Череповец(8202)49-02-64,  
Ярославль(4852)69-52-93

## Описание на цилиндрические датчики давления. Модель 165855



**BENTLY**  
Nevada

# 165855 Cylinder Pressure Transducer

Bently Nevada\* Asset Condition Monitoring

## Description

The Cylinder Pressure System consists of the 165855 Cylinder Pressure Transducer and the 146824 Interconnect cable. It is intended for measuring the cyclic absolute pressure changes inside a reciprocating compressor cylinder. This transducer is an integral part of a Reciprocating Compressor Condition Monitoring and Asset Management System when utilized with our 3500/77M Cylinder Pressure Monitor and System 1\* Plant Asset Management Software.

The Cylinder Pressure Transducer has a robust design for high reliability in harsh chemical environments. The unique, patent-pending design also allows the transducer to continue to provide an accurate pressure reading, even after being continually cycled over large pressure gradients for an extended period of time. The transducer can also withstand over-pressure situations caused by application upsets without diaphragm degradation, returning to normal operation when the operating pressure returns to the transducer's specified operating pressure range. The Cylinder Pressure Transducer is also designed to meet NEMA 4X and IP67 conditions for moisture ingress.

The wetted surface of the transducer is typically installed into an isolation valve or similar pressure indicator port on the compressor. A special adapter is usually required to provide a seal between the pressure indicator port and the transducer (such as the 166393 adapter). The electronics portion of the Cylinder Pressure Transducer is separated from the wetted surface by 1 metre of cable. The electronics must be secured on or near the compressor for optimal performance.

Each pressure sensor will be shipped with pressure-temperature compensation data in order to optimize the measurement. Inputting the supplied data points into the 3500/77 Cylinder Pressure Monitor can minimize the operating temperature effects on the transducer.

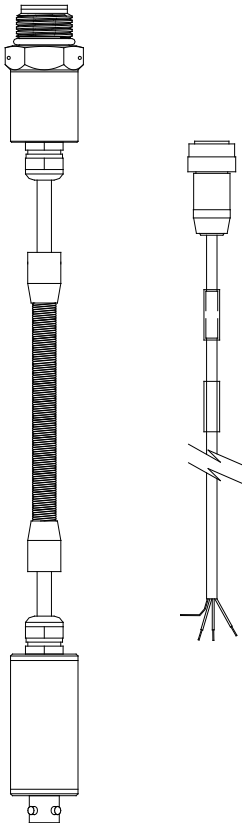

---

## Specifications

### Cylinder Pressure Transducer System

Operation outside the specified limits will result in false or inaccurate readings.

#### Transducer Characteristics:

##### Measurement Range:

0 to 100/ 250/ 500/ 1000/ 2500/  
5000/ 10,000 *psia*

0 to 6.8/ 17/ 34.5/ 69/172/ 345/  
689 *bar*

##### Proof (Over) Pressure:

1.5X Full Scale

##### Burst Pressure:

3X Full Scale (2X FS on 689 bar/  
10,000 *psia* units)

##### Full Scale Output:

10 ± 0.3 *Vdc*

##### Zero:

0.5 ± 0.1 *Vdc*

##### Power Supply:

18 to 30 *Vdc*

##### Max. Current:

< 15 *mA*

##### Compensated Temperature:

-40 to 85 °C

-40 to 185 °F

##### Thermal zero shift:

-1.0 to +2.0 (for 6.8 and 17 bar/  
100 and 250 *psia*) %FS

-0.5 to +1.5 (for all other pressure  
ranges)

**Note:** Within compensated  
temperature range.

##### Thermal sensitivity shift:

See diagram

##### Linearity, hysteresis, repeatability

≤ ±0.3 %FS

##### Frequency response:

0Hz to 5500 Hz ± 1 dB

##### Operating Temperature:

-40 to 85 (electronics housing) °C

-40 to 150 (sensor head) °C

-40 to 185 (electronics housing) °F

-40 to 302 (sensor head) °F

---

## Physical & Environmental

##### Weight:

250 g (0.55 lbm)

Sensor Head 150 g (0.33 lbm)

##### Dimensions:

See diagram

##### Materials:

Gold plated, per MIL-G-45204  
Type III Grade A, C-276 welded to  
a 316L stainless steel body.  
(patent pending)

##### Humidity:

95% condensing on exposed  
surfaces excluding connector

##### Body:

Designed to meet IP67

##### Operating Temperature:

Dependent upon O-ring material

Hifluor®: -26°C to 150°C (-15°F to  
302°F)

Ethylene Propylene:

-40°C to 150°C (-40°F to 302°F)

---

Specifications and Ordering Information  
Part Number 166815  
Rev. J (05/14)

## Pressure Media:

Fluid media compatible with C-276 and either Hifluor<sup>®</sup> or Ethylene Propylene o-ring material (common media below)

---

## O-rings:

**Note:** The o-ring utilized must be compatible with the type of gas or fluid that the transducer will be operated in. Consult your local representative for additional assistance.

## Hifluor<sup>®</sup> (black):

Hydrogen sulfide, sulfuric acid, butane, fuel oil, petroleum oil, turbine oil, propane, propylene, butylenes, and natural gas.

## Ethylene Propylene (purple):

Ammonium hydroxide, anhydrous ammonia

## Mounting Torque:

68 N-m (50 lbf-ft)

---

## EMC Directives

### Electrostatic Discharge:

EN 61000-4-2, Criteria B

### Radiated Susceptibility:

EN 61000-4-3, Criteria A

### Conducted Susceptibility:

EN 61000-4-6, Criteria A

### Electrical Fast Transient:

EN 61000-4-4, Criteria B

### Surge Capability:

EN 61000-4-5, Criteria A

### Magnetic Field:

EN 61000-4-8, Criteria A

---

## Patents

Components or procedures defined in this patent apply to this product.

---

## Ordering Information

### 165855 Cylinder Pressure Transducer

(All transducers have 7/8-14 UNF thread and are supplied with North American and ATEX approvals.)

#### 165855-AXX

#### A: Pressure Range Option

<b>01</b>	0 to 6.8 bar (0 to 100 psia)
<b>02</b>	0 to 17 bar (0 to 250 psia)
<b>03</b>	0 to 34.5 bar (0 to 500 psia)
<b>04</b>	0 to 69 bar (0 to 1,000 psia)
<b>05</b>	0 to 172 bar (0 to 2,500 psia)
<b>06</b>	0 to 345 bar (0 to 5,000 psia)
<b>07</b>	0 to 689 bar (0 to 10,000 psia)
<b>11</b>	0 to 6.8 bar (0 to 100 psia) w/ armor
<b>12</b>	0 to 17 bar (0 to 250 psia) w/ armor
<b>13</b>	0 to 34.5 bar (0 to 500 psia) w/ armor
<b>14</b>	0 to 69 bar (0 to 1,000 psia) w/ armor
<b>15</b>	0 to 172 bar (0 to 2,500 psia) w/ armor
<b>16</b>	0 to 345 bar (0 to 5,000 psia) w/ armor
<b>17</b>	0 to 689 bar (0 to 10,000 psia) w/ armor

---

### 146824 Cylinder Pressure Transducer Cable

#### 146824-AXXXX

#### A: Length Option

<b>0010</b>	10 ft (3 m)
<b>0025</b>	25 ft (7.6 m)
<b>0050</b>	50 ft (15.2 m)
<b>0100</b>	100 ft (30.5 m)
<b>0200</b>	200 ft (61.0 m)
<b>0300</b>	300 ft (91.4 m)
<b>0400</b>	400 ft (121.9 m)
<b>0500</b>	500 ft (152.4 m)
<b>1000</b>	1,000 ft (304.8 m)

---

## Hazardous Area Approvals

### CSA/NRTL/C

A/Ex ia IIC Class I Zone 0  
Class I, Div. 1  
Groups A, B, C, D  
T4 @ Ta = -40 °C to +85 °C

A/Ex nA IIC Class I Zone 2  
Class I, Div 2, Groups A,B,C,D  
T4 @ Ta = -40 °C to +85 °C

### ATEX

 II 1 G  
Ex ia IIC T4  
T4 @ Ta = -40°C to +85°C  
(-4°F to +150°F)

 II 3 G  
Ex nA II T4  
T4 @ Ta = -40°C to +85°C

### IECEX

IECEX CSA 10.0014  
EX ia IIC T4 Ga  
Ex na IIC T4 Gc  
IP67  
T4 = -40 °C ≤ Ta ≤ +85 °C

### Brazil

Ex ia IIC T4 Ga  
DNV 12.0101C  
Ex ic IIC T4 Gc  
DNV 12.0102x  
-40°C ≤ Ta ≤ +85°C

---

## Accessories

### 29660-01

Mounting clamp for electronics housing

### 166393-01

¾-14 NPT Adapter

### 166393-02

½-14 NPT Adapter

### 166820

Cylinder Pressure Manual

### 04500022

ADH Dow 4 Elec Ins Comp 4cc Tub

### 3500/77M

Cylinder Pressure Monitor

---

## Notes

-  165855 designed to mate per SAE J1926. Transducer will not seal pressure sufficiently if not mated per SAE J1926.
- Transducer diaphragm may become damaged upon contact with any foreign object. Care must be taken to protect diaphragm during handling and installation to help ensure proper performance.
- O-ring must be adequately lubricated with supplied Parker Super-O-Lube prior to installation.
- Depending upon application, acoustic resonance may occur. For specific details on acoustic resonance and indicator valves, contact your local sales or service representative for more information.
- It is highly recommended that an isolation valve be used in conjunction with the 165855 Cylinder Pressure Transducer. Valve materials must be compatible with sour gas environments.

# Graphs and Dimensional Drawings

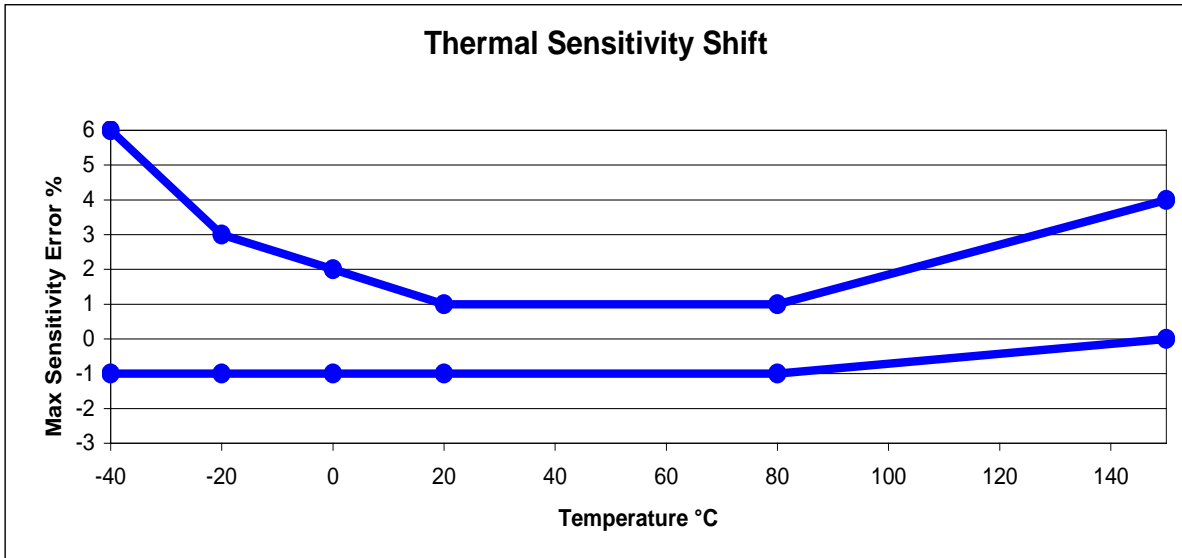

Figure 1. Typical Thermal Sensitivity Shift

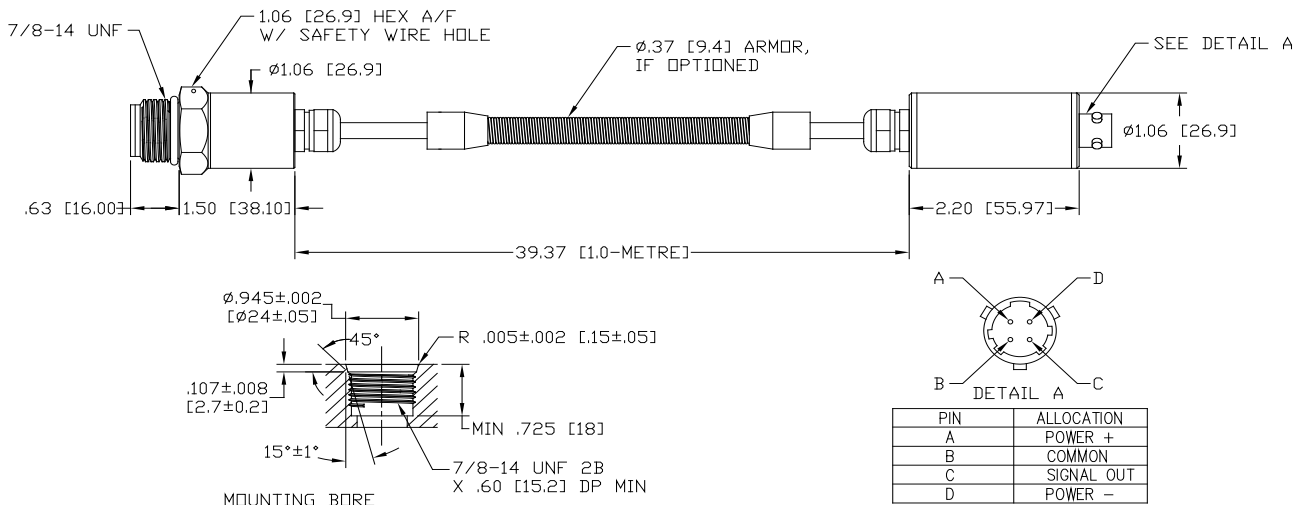
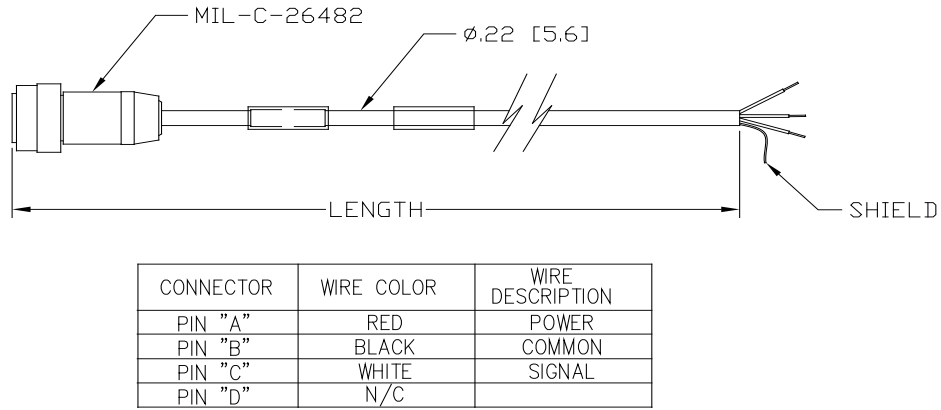
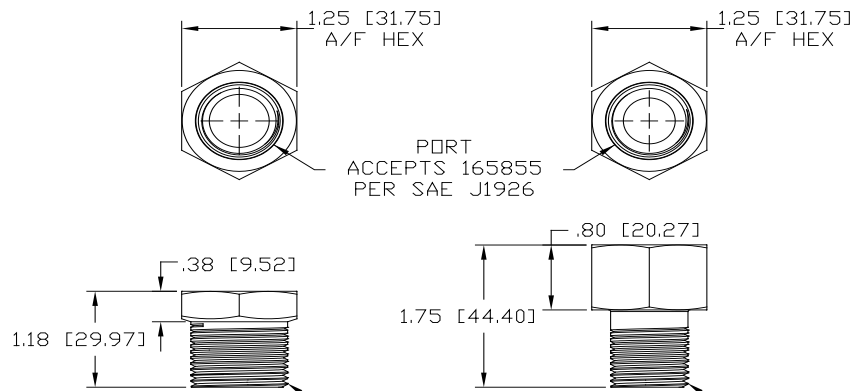

Figure 2. 165855-AA Cylinder Pressure Transducer and bore per SAE J1926



**Figure 3. 146824-AAAA Cylinder Pressure Cable**



Adapter notes:

1. The 166393-AA adapter is rated to 345 bar (5,000 psi) per ASME B31.1.
2. When exceeding 345 bar (5,000 psi), the 166393-AA is not recommended. In applications exceeding 345 bar (5,000 psi), direct mounting of the 165855 transducer per SAE J1926 is highly recommended.

**Figure 4. 166393-AA Adapter**

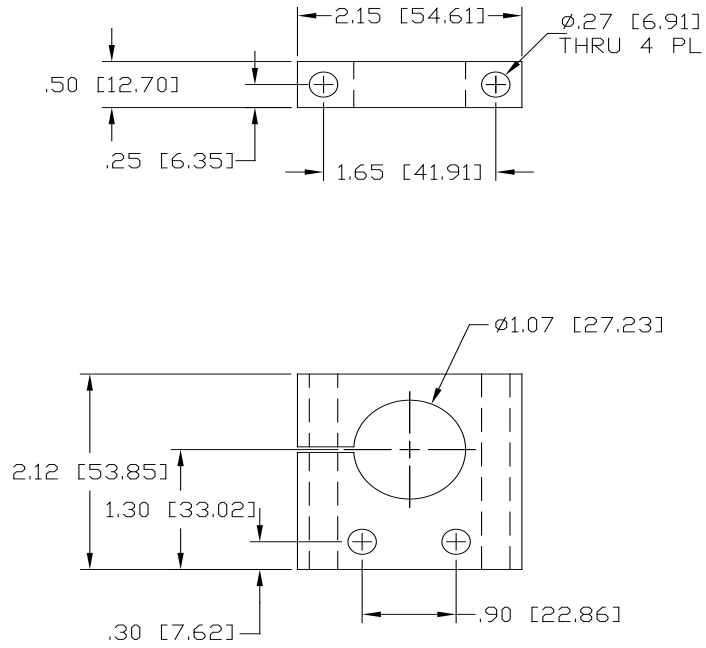

**Figure 5. 29660-01 Mounting Clamp, use with M6 or ¼-20 (not supplied)**



По вопросам продаж и поддержки обращайтесь: [btn@nt-rt.ru](mailto:btn@nt-rt.ru)

[www.bently.nt-rt.ru](http://www.bently.nt-rt.ru)

Архангельск (8182)63-90-72,  
Астана+7(7172)727-132,  
Белгород(4722)40-23-64,  
Брянск(4832)59-03-52,  
Владивосток(423)249-28-31,  
Волгоград(844)278-03-48,  
Вологда(8172)26-41-59,  
Воронеж(473)204-51-73,  
Екатеринбург(343)384-55-89  
, Иваново(4932)77-34-06,  
Ижевск(3412)26-03-58,  
Казань(843)206-01-48,  
Калининград(4012)72-03-81,  
Калуга(4842)92-23-67,  
Кемерово(3842)65-04-62,  
Киров(8332)68-02-04,

Краснодар(861)203-40-90,  
Красноярск(391)204-63-61,  
Курск(4712)77-13-04,  
Липецк(4742)52-20-81,  
Магнитогорск(3519)55-03-13,  
Москва(495)268-04-70,  
Мурманск(8152)59-64-93,  
Набережные Челны(8552)20-53-41  
, Нижний Новгород(831)429-08-12,  
Новокузнецк(3843)20-46-81,  
Новосибирск(383)227-86-73,  
Орел(4862)44-53-42,  
Оренбург(3532)37-68-04,  
Пенза(8412)22-31-16,  
Пермь(342)205-81-47,  
Ростов-на-Дону(863)308-18-15,

Рязань(4912)46-61-64,  
Самара(846)206-03-16,  
Санкт-Петербург(812)309-46-40,  
Саратов(845)249-38-78,  
Смоленск(4812)29-41-54,  
Сочи(862)225-72-31,  
Ставрополь(8652)20-65-13,  
Тверь(4822)63-31-35,  
Томск(3822)98-41-53,  
Тула(4872)74-02-29,  
Тюмень(3452)66-21-18,  
Ульяновск(8422)24-23-59,  
Уфа(347)229-48-12,  
Челябинск(351)202-03-61,  
Череповец(8202)49-02-64,  
Ярославль(4852)69-52-93



**BENTLY**  
Nevada